

**Extruded Aluminum Damper • 5" Deep • 6" Airfoil Blade • Opposed or Parallel • Thermal Break**

### STANDARD CONSTRUCTION

**FRAME:** 5" wide x .081" thick (nominal) 6063-T52/T6 extruded aluminum, hat shaped channel.

**BLADES:** 6" wide x .081" thick (nominal) 6063-T52/T6 extruded aluminum, airfoil profile injected with a two part polyurethane (CFC free) foam, and debridged for thermal isolation.

**AXLES:** 1/2" dia. extruded aluminum, "Pin-Lock" design, interlocking into blade section.

**LINKAGE:** Concealed in jamb of heavy aluminum. Crank arm permanently locked to blade axle by two stainless steel fasteners. The crank arm contains a 1/2" dia. metal pivot riding in a celcon bearing. A 1/4 - 20 set screw with locking patch ties the 5/16" dia. aluminum linkage rod. The linkage of each damper is individually adjusted.

**BEARINGS:** "Double-sealed" type with celcon inner bearing riding inside a polycarbonate outer bearing positively locked into frame, designed so that there shall be no metal-to-metal or metal-to-bearing riding surfaces.

**SEALS:** Extreme low temperature seal system, extruded silicone rubber blade edge seal that fits into a ribbed groove insert in blades with an extruded polycarbonate seal at jambs.

**FINISH:** Mill

**TEMP. LIMITS:** -40°F to +200°F

### OPTIONS

- Frame - Optional .125" thick nominal 6063-T6/T52 extruded aluminum
- Hand Quadrants
- 120V, 24V Electric, or Pneumatic Actuators
- Jackshifting
- Auxiliary Switch
- Explosion Proof Housing

### NOTES

1. Nominal deductions will be made to the opening size given.
2. Dampers with multiple panels in both width and height may require structural support. It is recommended that large openings be designed with structural members so that dampers will span either width or height with a single panel. Structural support will not be provided with standard dampers.
3. Dampers more than one panel wide or high and operated with one actuator must be jackshafed. Factory supplied actuators are shipped loose to be mounted external as standard.
4. Not recommended for blades installed vertically.
5. Approximate damper weight is 6.5 lbs./sq.ft.

### DAMPER SIZES

Blade Type	Minimum Panel	Maximum Panel
Parallel	6"W x 8 7/8"H	60"W x 72"H
Opposed	6"W x 8 7/8"H	60"W x 72"H

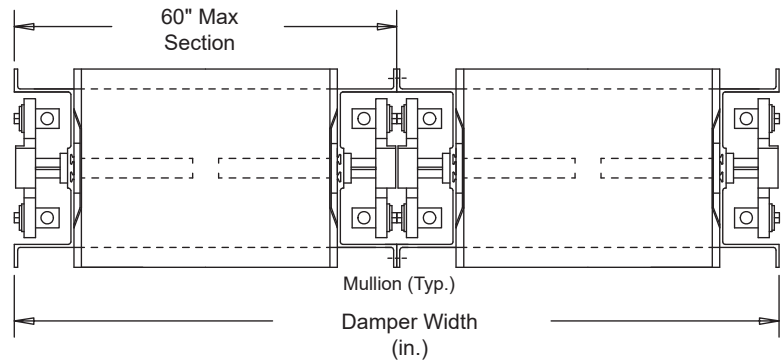
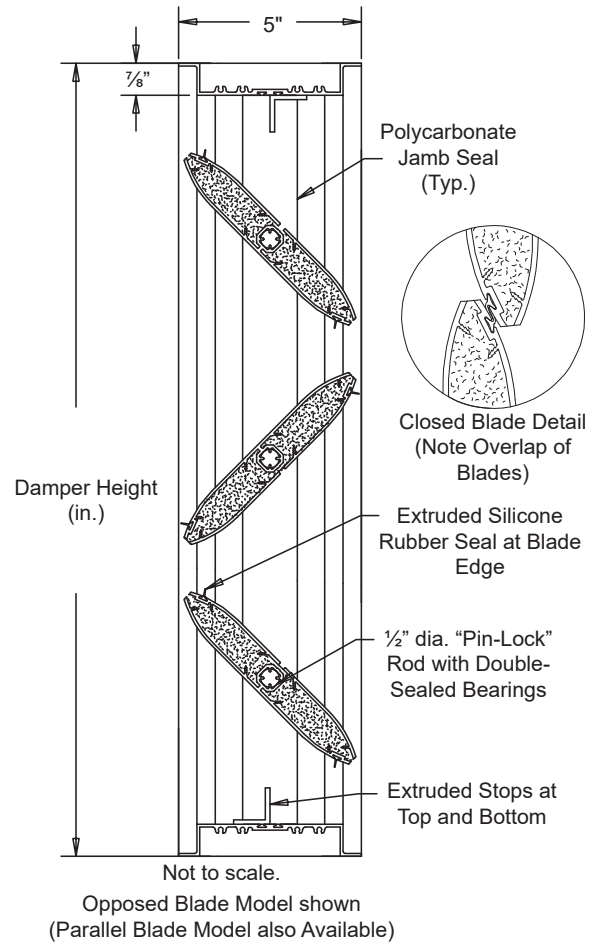

Item #	Qty	Width	Height	Para.	Oppo.	Actuator Model	Interior	Exterior	N.C.	N.O.	Union Made
		Damper Size		Blade Position			Location		Function		
Arch. / Eng.:						EDR:		ECN:		Job:	
Contractor:											
Project:						Date:		DWN:		DWG:	

In the interest of product development, Louvers & Dampers reserves the right to make changes without notice.



Extruded Aluminum Damper • 5" Deep • 6" Airfoil Blade • Opposed or Parallel • Thermal Break

## PERFORMANCE DATA

Pressure Drop Ratings are tested in accordance with AMCA Standard 500-D using test set-up Fig. 5.3 for damper installed with duct upstream and downstream. Static pressures are corrected to .075 lb./cu.ft. air density.

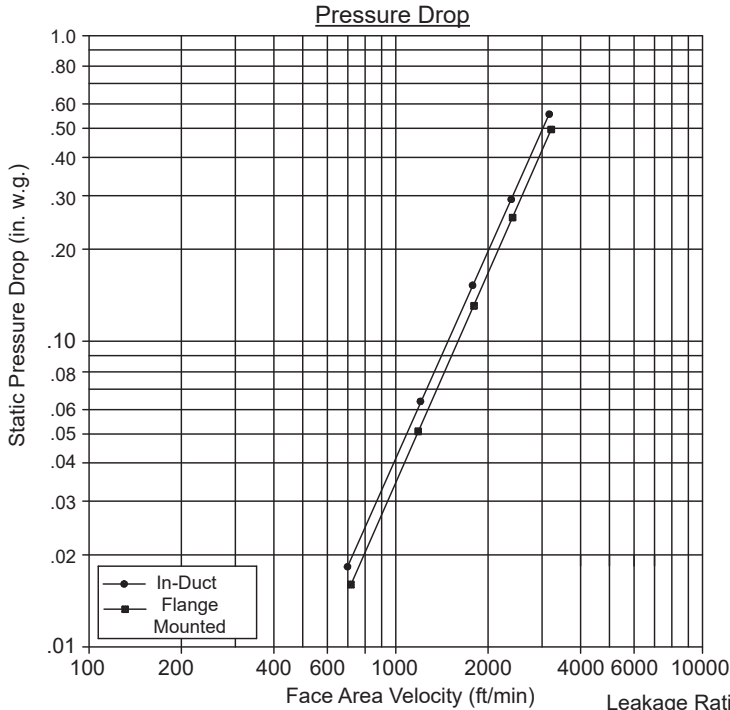

## LEAKAGE

Total cfm Leakage at 1 in. w.g. Static Pressure Differential

		Width				
		12"	24"	36"	48"	60"
Height	12"	2	4	6	8	10
	18"	3	6	9	12	15
	24"	4	8	12	16	20
	30"	5	10	15	20	25
	36"	6	12	18	24	30
	42"	7	14	21	28	35
	48"	8	16	24	32	40
	54"	9	18	27	36	45
	60"	10	20	30	40	50
	66"	11	22	33	44	55
72"	12	24	36	48	60	

Leakage Ratings are tested in accordance with AMCA Standard 500-D using test set-up Fig. 5.4. Data is based on a closing torque of 5 in.lb./sq.ft. for dampers less than 5 sq.ft. having a closing torque of 40 in.lb. damper closing torque is applied to damper operating shaft.

## Leakage Correction Factor

Damper Width (in.)	Static Pressure in.wg						
	2"	3"	4"	5"	6"	7"	8"
12" - 60"	1.44	1.64	2.00	2.22	2.44	2.64	2.82

Use of correction factors will give leakage values at greater than 1" pressures.

## Damper Limitations

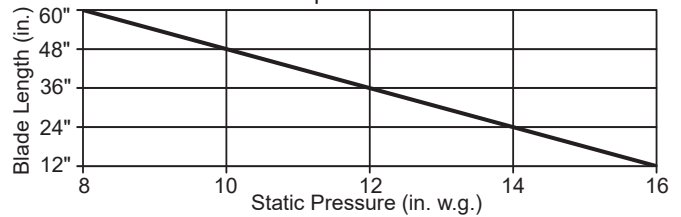

Model T28B damper design at reduced lengths can withstand higher static pressure limits without sacrificing damper operation and performance. Static pressures above 8 in. w.g. will affect operation torque value.

## Thermal Performance

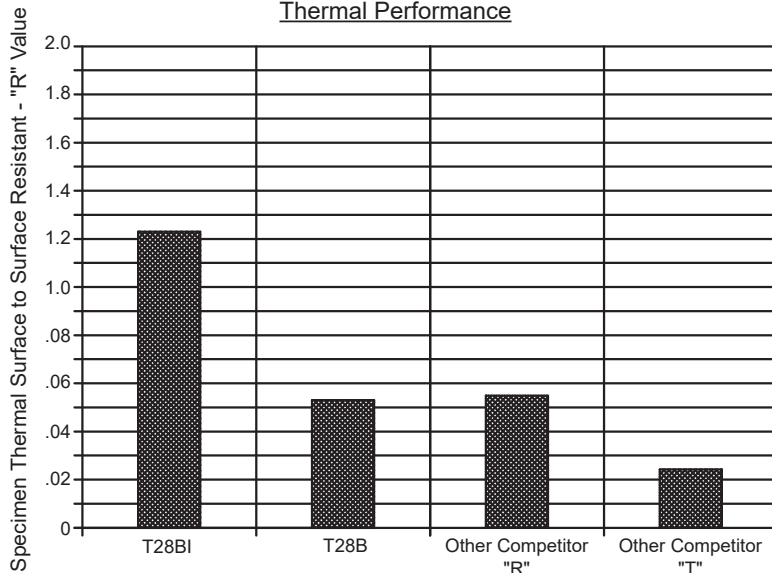

Damper Assembly Thermal Performance Rating Tested to ASTM C-1363-97, Standard Test Method for Thermal Performance of Building Assemblies by Means of a Hot Box Apparatus and Replaces C236 and C-975 Test Methods.